



Lane Machine Manual

REV 1:20

Crossfire Specifications

17-5200C Crossfire
Class I - Single Phase
115 Volts, 60 Hz, 20 Amps

17-5250C Crossfire
Class I - Single Phase
230 Volts, 50 Hz, 15 Amps

Machine Dimensions

Width – 55 1/4" (140.34 cm)
Height - 15 1/2"
Length - 38 3/4"
Weight: Crossfire- 265 pounds

Manual Part Number: 158-5200C
Omron CPL1 First Edition
PLC Software 5.1

CHAPTER 7



Mechanical Drawings

Machine Descriptions and Part Numbers

The following figures show major systems for the Crossfire and the associated parts:

Figure 1 – Crossfire (Top View)	70
Figure 2 – Crossfire (Bottom View).....	72
Figure 3 – Crossfire (Right Side)	74
Figure 4 – Crossfire (Left Side).....	76
Figure 5 – Wick and Oil Transfer Assembly.....	78
Figure 5A – Wick and Oil Transfer Upgrade Assembly.....	80
Figure 6 – PC Relay Plate Assembly	82
Figure 7 – Vacuum Assembly	84
Figure 8 – Squeegee Assembly	86
Figure 9 – LDS Assembly	88
Figure 10 – Duster Cloth Assembly	90
Figure 11 – Cleaner Supply Assembly	92
Figure 12 – Brush Lift Assembly	94

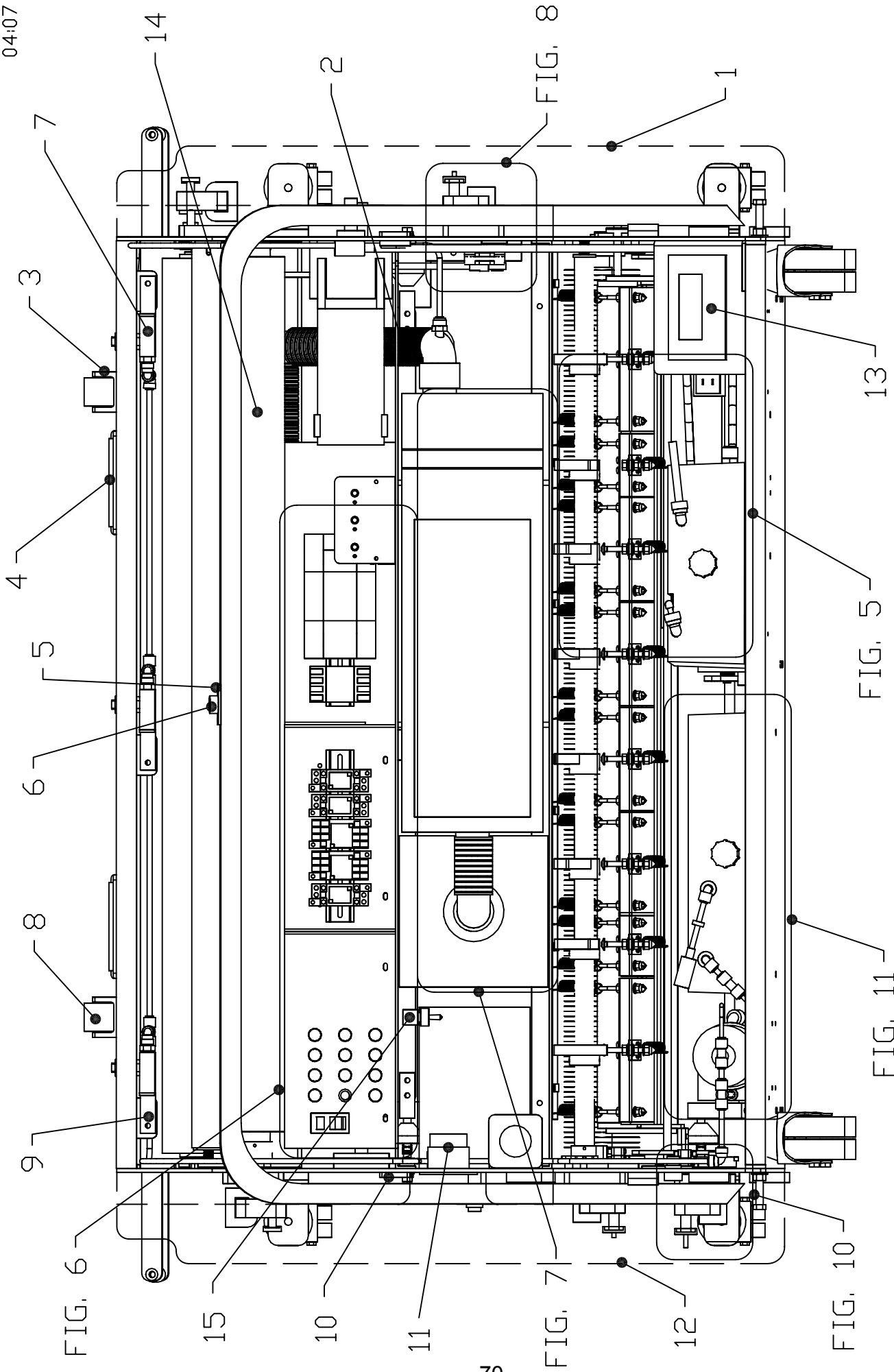

FIGURE 1

FIGURE 1 PART NUMBERS			
FIGURE	INDEX	PART	PART NAME & DESCRIPTION
NUMBER	NUMBER	NUMBER	
1	1	158-6249	GUARD FOR CROSSFIRE - RIGHT (PLASTIC)
1	2	154-0260	FLEXIBLE VACUUM HOSE GRAY (1-1/2 INCH ID)
1	3	153-6029	MOMENTARY WHEEL HOUSING
1	4	154-0810	LIFTING HANDLE (SS SPRING-LOADED CHEST)
1	5	153-6437	PUSH BUTTON MOUNTING PLATE
1	6	158-8203	BUTTON ASSEMBLY - CROSSFIRE
1	7	153-6252	SPRAY JET BODY
1	8	153-8311	MOMENTARY WHEEL ASSEMBLY (URETHANE)
1	9	153-6251S	SPRAY JET SWIVEL MOUNTING ANGLE
1	10	154-6698	LID MOUNT PLATE
1	11	153-1823	FLANGED TWISTLOCK INLET - 125V/20A
1	11	153-1826	FLANGED TWISTLOCK INLET - 250V/20A
1	12	158-6248	GUARD FOR CROSSFIRE - LEFT (PLASTIC)
1	13	154-8806	KEYPAD ASSEMBLY FOR CROSSFIRE
1	14	153-0047EZ	DUSTER CLOTH - KEGEL SELECT
1	15	154-1811	TOGGLE SWITCH SPDT ON-OFF-ON

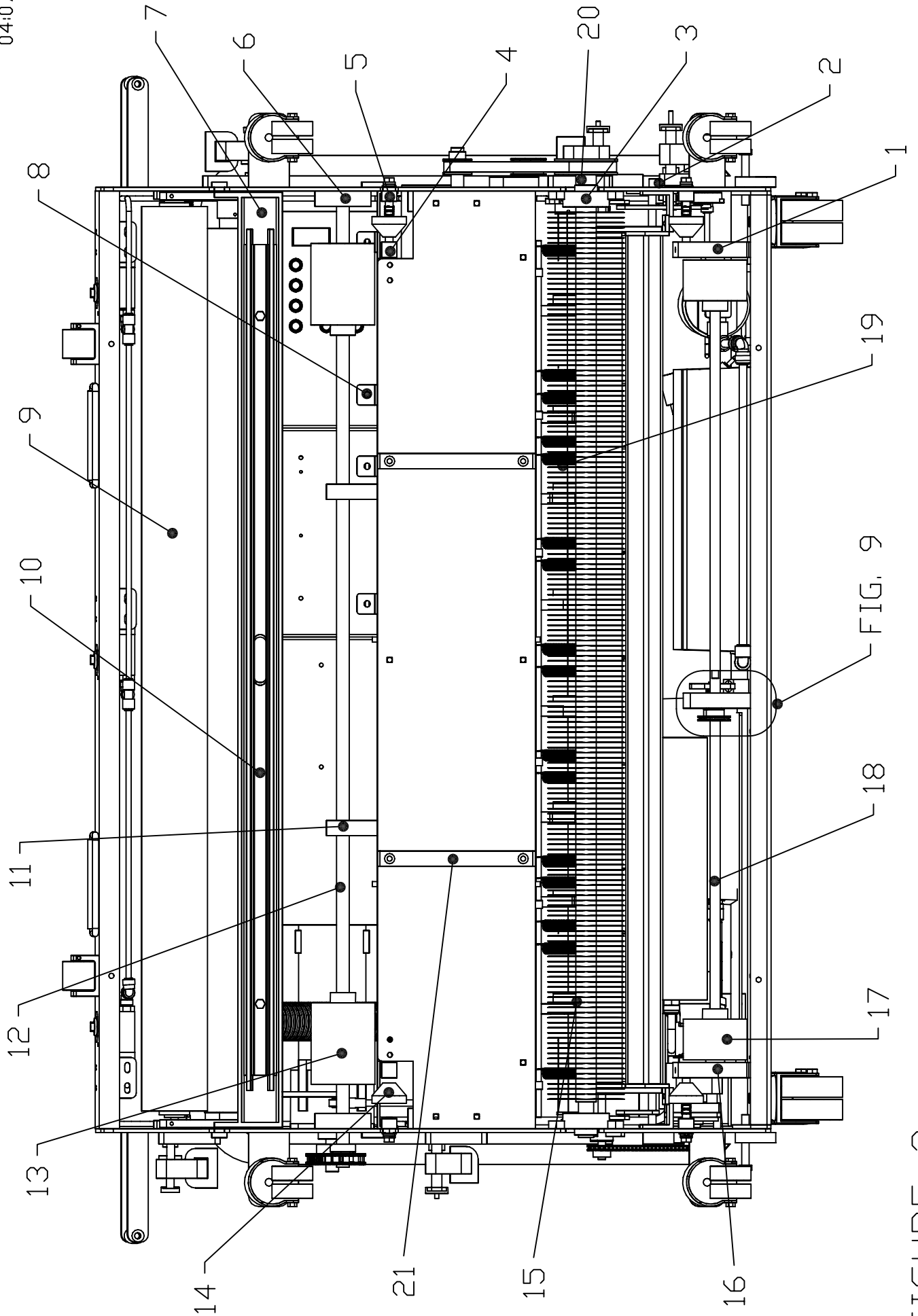

FIG. 9

FIGURE 2

FIGURE 2 PART NUMBERS			
FIGURE	INDEX	PART	PART NAME & DESCRIPTION
NUMBER	NUMBER	NUMBER	
2	1	154-8619	PILLOWBLOCK-LANE DISTANCE (LEFT-FLANGED)
2	2	153-1408	PUSH BUTTON (RED = NORMALLY OPEN)
2	3	154-8640	FLANGED BEARING FOR BUFFER BRUSH (3/4" ROTATED)
2	4	154-6651	FRONT GUIDE ROLLER MOUNT
2	5	154-6652	GUIDE ROLLER MOUNT BLOCK
2	6	154-8007	SIDE PLATE PILLOWBLOCK FOR DRIVE SHAFT
2	7	154-6339-2133	SQUEEGEE MOUNT ANGLE (PAINTED)
2	8	154-6827	PLC RELAY MOUNT PLATE ANGLE
2	9	153-8838	CUSHION ROLLER (STEEL=44-3/8)
2	10	153-0202	COMPLETE SQUEEGEE ASSEMBLY (BLUE)
2	10	153-0202B	REPLACEMENT SQUEEGEE BLADE-BLUE
2	11	154-8803	DRIVE SHAFT PILLOWBLOCK
2	12	158-6237	DRIVE SHAFT - CROSSFIRE
2	13	153-7013	URETHANE-BLEND LANE DRIVE WHEEL (4")
2	14	153-8410	LANE EDGE GUIDE ROLLER W/BUSHING (1/2")
2	15	154-8641	BUFFER BRUSH (BLUE 3-3/4" X 48)
2	16	154-8621	PILLOWBLOCK-LANE DISTANCE (RIGHT-FLANGE)
2	17	153-7002AA	LANE DISTANCE COUNTER WHEEL-TREADED (2")
2	18	154-6821	LDS SHAFT
2	19	153-2740	SPRING (WICK PLATE)
2	20	154-6664	BUFFER BRUSH PULLEY SPACER

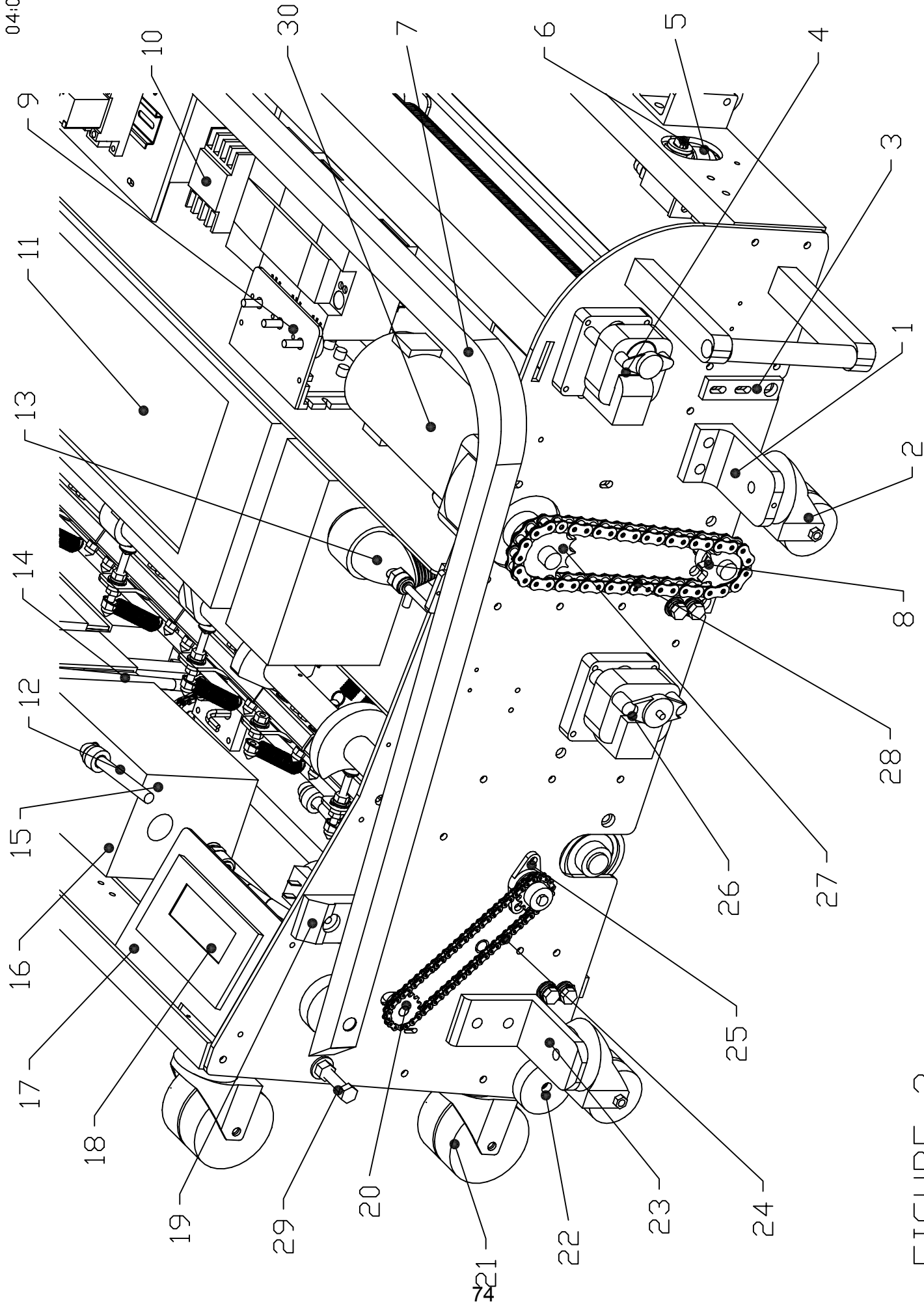

FIGURE 3

FIGURE 3 PART NUMBERS			
FIGURE NUMBER	INDEX NUMBER	PART NUMBER	PART NAME & DESCRIPTION
3	1	158-6232	FRONT CASTER MOUNT ANGLE - CROSSFIRE
3	2	153-0812	TRANSPORT CASTER-2" HEAVY DUTY (3/8")
3	3	154-8801	SQUEEGEE ADJUSTMENT ARM
3	4	153-8403	BRAKE MOTOR ASSEMBLY (7 RPM-115V 60 Hz)
3	4	153-8803H	BRAKE MOTOR ASSEMBLY (7 RPM-230V 50 Hz)
3	5	158-6254	SPRAY JET SUCTION CUP
3	6	154-0007	SPRAY TIP - STAINLESS STEEL (1501)
3	7	158-8202	HANDLE ASSEMBLY - CROSSFIRE
3	8	153-9003	SPROCKET - 40B10 (5/8")
3	9	158-8211	SPEED CONTROL ASSEMBLY (115V/230V 3 SPEED)
3	10	153-1004	BUFFER MOTOR CONTACTOR (115 VOLT)
3	10	153-1604	BUFFER MOTOR CONTACTOR (230 VOLT)
3	11	153-8841	RECOVERY TANK ASSEMBLY - MOLDED
3	12	154-0832	GARDEN HOSE FITTING CAP W/ GASKET
3	13	158-6244	ELBOW - RECOVERY TANK W/TAPPED HOLE
3	14	154-8320	PILLOWBLOCK - LANE DISTANCE SHAFT (CENTER-PLAIN)
3	15	158-0201	GARDEN HOSE FITTING 1/2 INCH BARB
3	16	158-6217	OIL FILL MOUNT - CROSSFIRE
3	17	158-6242	KEYPAD MOUNT PLATE
3	18	158-8253	KEYPAD ASSEMBLY FOR CROSSFIRE
3	19	154-6041	UHMW HANDLE STOP
3	20	153-9010	SPROCKET-25B15 (5/16")
3	21	153-0001	TRANSPORT CASTER (3" DUAL WHEEL)
3	22	154-6042	UHMW WHEEL - CORNER GUARD
3	23	154-6221	MOUNTING ANGLE - HEAVY DUTY CASTER (3 x 3.625)
3	24	158-9204	TRANSFER ROLLER DRIVE CHAIN (25P61)
3	25	154-9804	FLANGED BEARING FOR CLEANER DRIVE SHAFT
3	26	153-8207	BRAKE MOTOR ASSEMBLY (25 RPM-115V 60Hz)
3	26	153-8807H	BRAKE MOTOR ASSEMBLY (25 RPM-230V 50 Hz)
3	27	153-9002	SPROCKET - 40B13 (5/8")
3	28	158-9203	DRIVE CHAIN 40P39
3	29	153-2818	HHCS - 3/8-16 X 2-1/2 (GRADE 8)
3	30	154-8865	DRIVE MOTOR ASSEMBLY

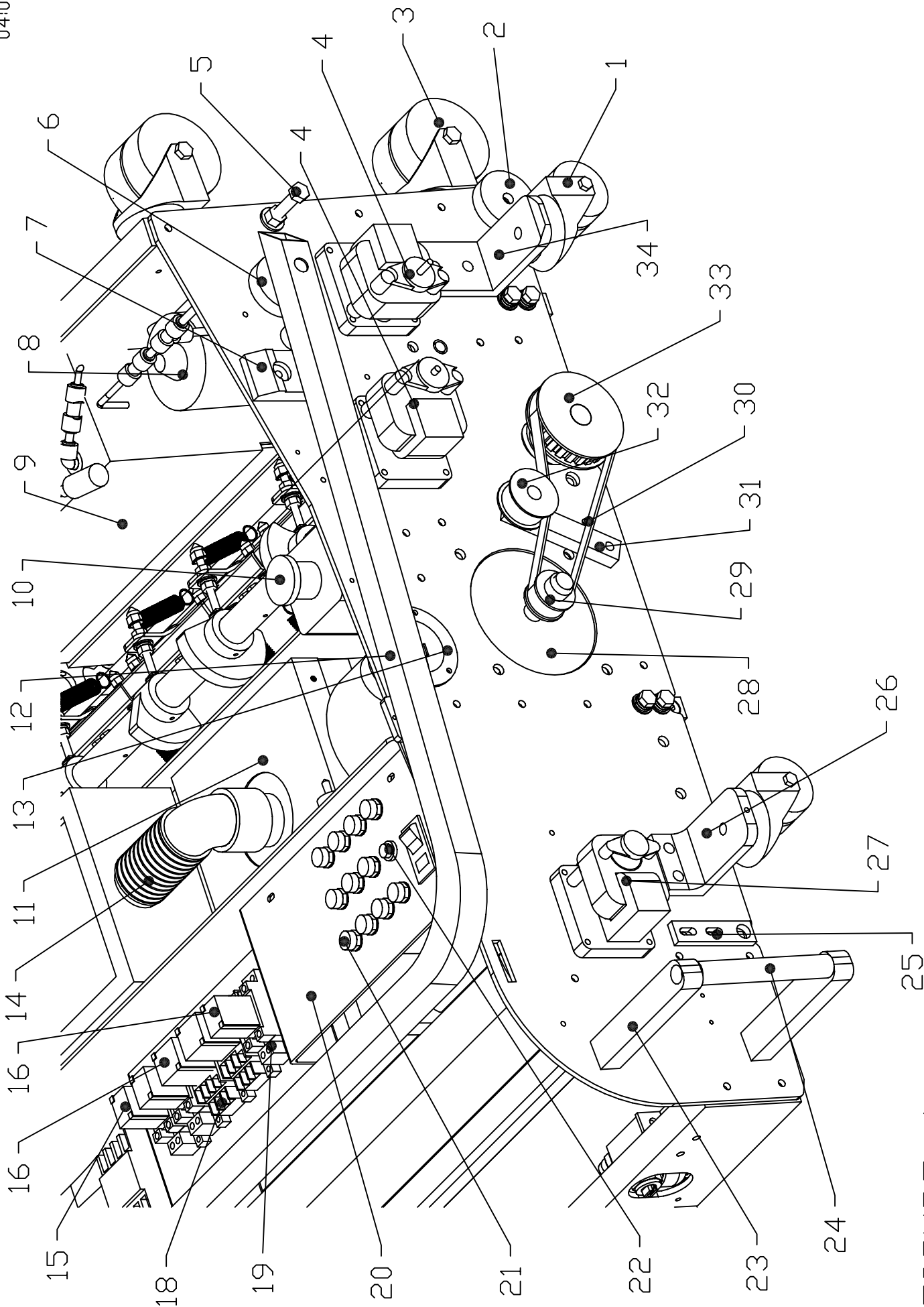

FIGURE 4

FIGURE 4 PART NUMBERS			
FIGURE NUMBER	INDEX NUMBER	PART NUMBER	PART NAME & DESCRIPTION
4	1	153-0812	TRANSPORT CASTER-2" HEAVY DUTY (3/8")
4	2	154-6042	UHMW WHEEL - CORNER GUARD
4	3	153-0001	TRANSPORT CASTER (3" DUAL WHEEL)
4	4	153-8207	BRAKE MOTOR ASSEMBLY (25 RPM-115V 60Hz)
4	4	153-8807H	BRAKE MOTOR ASSEMBLY (25 RPM-230V 50 Hz)
4	5	153-2818	HHCS - 3/8-16 X 2-1/2 (GRADE 8)
4	6	153-6851	UHMW HANDLE SPACER
4	7	154-6041	UHMW HANDLE STOP
4	8	153-8206F	WATER PUMP-Kegel 115v
4	8	153-8206H	WATER PUMP-Kegel 230v
4	9	154-6723	CLEANER SUPPLY TANK (NO FITTINGS)
4	9	154-8840	CLEANER SUPPLY TANK (COMPLETE)
4	10	154-1250	EMERGENCY STOP CIRCUIT BREAKER ASSEMBLY
4	11	158-6212	VACUUM MOTOR TOP PLATE - CROSSFIRE
4	12	158-8202	HANDLE ASSEMBLY - CROSSFIRE
4	13	153-1823	FLANGED TWISTLOCK INLET - 125V/20A
4	13	153-1826	FLANGED TWISTLOCK INLET - 250V/20A
4	14	154-0260	FLEXIBLE VACUUM HOSE STOCK (1-1/2" ID)
4	15	153-1020	LY2 RELAY (24VDC)
4	16	153-1016	LY2 RELAY (115 VOLT)
4	16	153-1616	LY2 RELAY (230 VOLT)
4	17	153-1018	LY3 RELAY (115 VOLT)
4	17	153-1618	LY3 RELAY (230 VOLT)
4	18	153-1019	LY3 RELAY BASE
4	19	153-1017	LY2 RELAY BASE
4	20	158-6216	PLC/RELAY MOUNT PLATE
4	21	153-1028	PANEL-MOUNT FUSE HOLDER - UL (COMPLETE)
4	21	153-1028E	PANEL-MOUNT FUSE HOLDER - IEC (COMPLETE)
4	22	153-1810	CIRCUIT BREAKER - SPST - 8 AMP (230V ONLY)
4	23	158-6241	SIDE LIFT HANDLE MOUNT BAR
4	24	154-6627	SIDE LIFT HANDLE
4	25	154-8801	SQUEEGEE ADJUSTMENT ARM
4	26	158-6232	FRONT CASTER MOUNT ANGLE - CROSSFIRE
4	27	153-8403	BRAKE MOTOR ASSEMBLY (7 RPM-115V 60Hz)
4	27	153-8803H	BRAKE MOTOR ASSEMBLY (7 RPM-230V 50 Hz)
4	28	154-8616A	BUFFER MOTOR ASSEMBLY (115V-AC ONLY)
4	28	154-8616E	BUFFER MOTOR ASSEMBLY (230V-AC ONLY)
4	29	153-9013	BUFFER MOTOR PULLEY (10L050-1/2")
4	30	158-9201	T-BELT 210L050 (BUFFER MOTOR)
4	31	154-6841	BUFFER IDLER MOUNT BAR
4	32	154-8839	BUFFER IDLER ASSEMBLY
4	33	153-9014	BUFFER PULLEY (24L050-3/4")
4	34	154-6221	MOUNTING ANGLE-HEAVY CASTER (3 X 3.625)

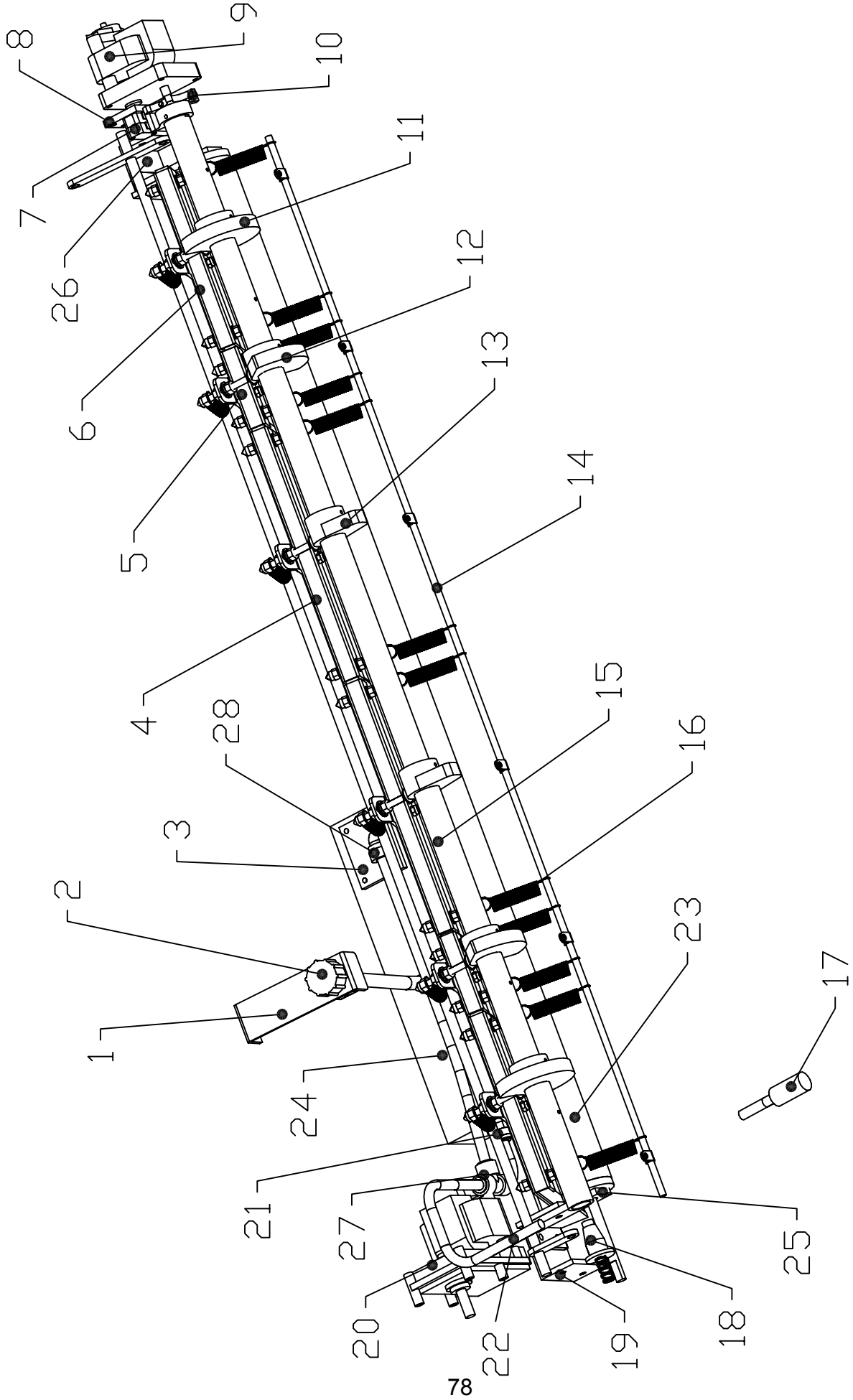

FIGURE 5

FIGURE 5 PART NUMBERS			
FIGURE	INDEX	PART	PART NAME & DESCRIPTION
NUMBER	NUMBER	NUMBER	
5	1	158-6217	OIL FILL MOUNT - CROSSFIRE
5	2	154-0832	GARDEN HOSE FITTING CAP W/ GASKET
5	3	158-6246	OIL TANK FLOAT COVER PLATE
5	4	158-8230	WICK PLATE ASSEMBLY 10.125 INCH - CROSSFIRE
5	5	158-8223	WICK PLATE ASSEMBLY 3.125 INCH - CROSSFIRE
5	6	158-8227	WICK PLATE ASSEMBLY 7.125 INCH - CROSSFIRE
5	7	153-1202	MICROSWITCH-WITHOUT ROLLER
5	8	154-6890	CAM SWITCH MOUNT PLATE
5	9	153-8207	BRAKE MOTOR ASSEMBLY (25 RPM-115 VOLT)
5	9	153-8807H	BRAKE MOTOR ASSEMBLY (25 RPM-230V 50 Hz)
5	10	158-6220	CAM POSITION 6 TOOTH TARGET - CROSSFIRE
5	11	158-6224	OUTSIDE PAD CAM - CROSSFIRE
5	12	158-6223	TRACK PAD CAM - CROSSFIRE
5	13	158-6222	INSIDE PAD CAM - CROSSFIRE
5	14	158-6239	WICK SPRING ROD - CROSSFIRE
5	15	158-6233	CAM SHAFT FOR 6-PAD - CROSSFIRE
5	16	153-2740	SPRING (WICK PLATE)
5	17	154-0211	FILTER FOR OIL TANK VENT VALVE
5	18	158-6221	CAM SHAFT PLUG
5	19	158-6228	WICK TROUGH MOUNT ANGLE - RIGHT
5	20	153-8828	TRANSFER ROLLER MOTOR - 50 RPM (115V)
5	20	153-8829	TRANSFER ROLLER MOTOR - 50 RPM (230V)
5	21	154-0410	FITTING - 3/8 TUBE X 3/8 NPT MALE
5	22	154-0202	PUMP TUBING STOCK (3/8" OD X 1/4" ID)
5	23	158-8204	TRANSFER ROLLER ASSEMBLY - CROSSFIRE
5	24	158-6210	WICK TROUGH WITH RESERVOIR
5	25	158-8210	TRANSFER ROLLER ARM ASSEMBLY
5	26	158-6227	WICK TROUGH MOUNT ANGLE - LEFT
5	27	154-0815	FITTING - 3/8 TUBE TEE
5	28	154-0225	ELBOW - 3/8 TUBE OD X 1/4 NPT

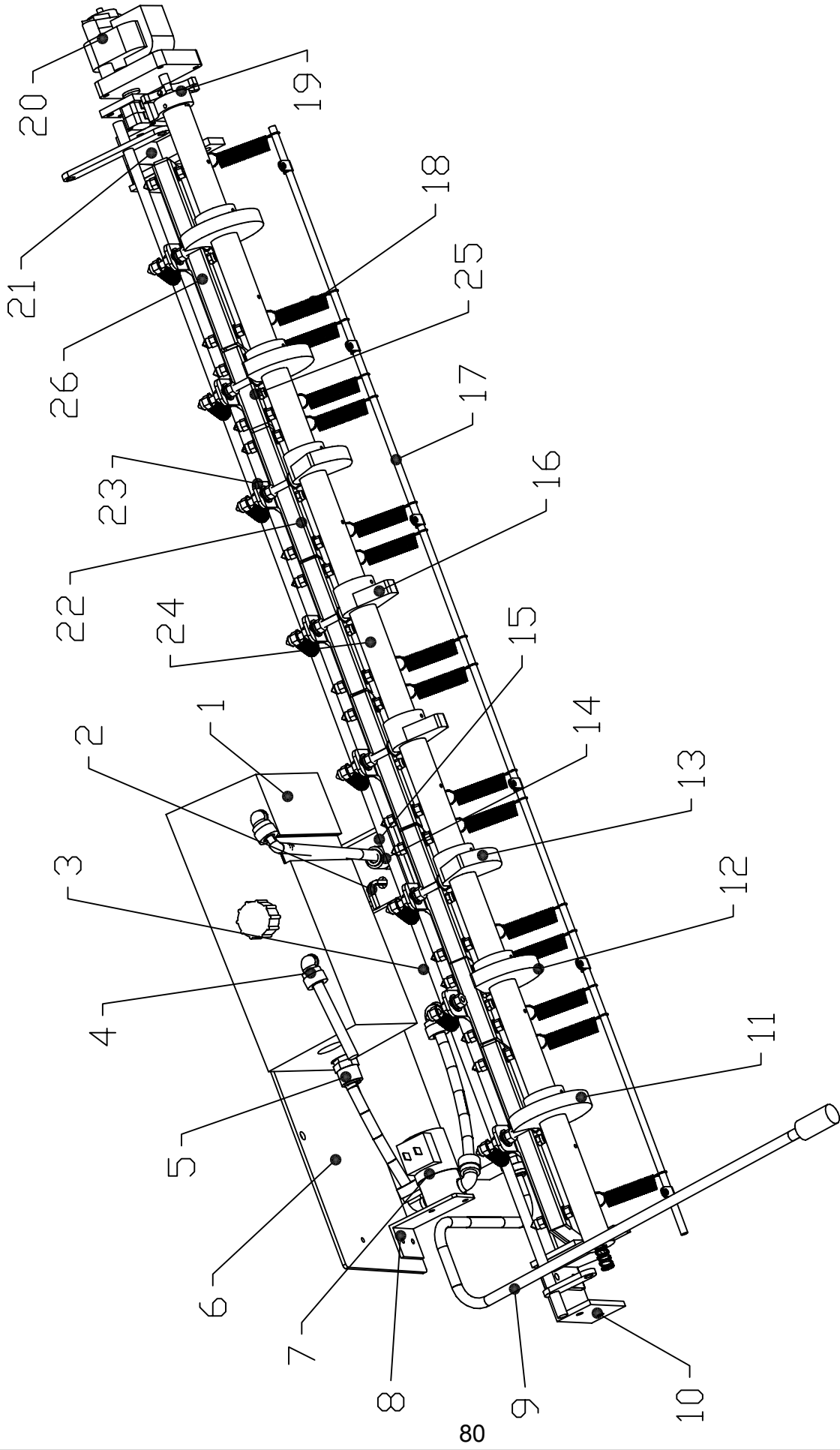

FIGURE 5A

FIGURE 5A PART NUMBERS			
FIGURE	INDEX	PART	PART NAME & DESCRIPTION
NUMBER	NUMBER	NUMBER	
5A	1	154-6724	POLY CONDITIONER SUPPLY TANK ONLY
5A	1	154-8342	POLY CONDITIONER TANK ASSEMBLY W/ FITTINGS
5A	2	154-1203	FLOAT SWITCH FOR OIL TANK - 24VDC
5A	3	158-6210	WICK TROUGH WITH RESERVOIR
5A	4	154-0225	ELBOW - 3/8 TUBE OD X 1/4 NPT
5A	5	154-0410	FITTING - 3/8 TUBE X 3/8 NPT MALE
5A	6	158-6219	OIL TANK UPGRADE PLATE
5A	7	154-8322	OIL VALVE ASSY- 115V AC 2-WAY (1/4" NPT)
5A	7	154-8323	OIL VALVE ASSY- 230V AC 2-WAY (1/4" NPT)
5A	8	154-6355	VALVE MOUNT ANGLE
5A	9	154-0202	PUMP TUBING STOCK (3/8" OD X 1/4" ID)
5A	10	158-6228	WICK TROUGH MOUNT ANGLE - RIGHT
5A	11	158-6253	OUTSIDE PAD CAM - ZONE 1
5A	12	158-6252	TRACK PAD CAM - ZONE 2
5A	13	158-6251	INSIDE PAD CAM - ZONE 3
5A	14	154-0814	FITTING - 1/4 NPT X 3/8 TUBE
5A	15	158-6245	OIL TANK FLOAT MOUNT PLATE
5A	16	158-6250	INSIDE PAD CAM - ZONE 4
5A	17	158-6239	WICK SPRING ROD - CROSSFIRE
5A	18	153-2740	SPRING - (WICK PLATE)
5A	19	158-6220A	CAM POSITION 8 TOOTH TARGET - CROSSFIRE
5A	20	153-8207	BRAKE MOTOR ASSEMBLY (25 RPM-115V 60Hz)
5A	20	153-8807H	BRAKE MOTOR ASSEMBLY (25 RPM-230V 50 Hz)
5A	21	158-6227	WICK TROUGH MOUNT ANGLE - LEFT
5A	22	158-8225	WICK PLATE ASSEMBLY 5.125 INCH - CROSSFIRE
5A	23	158-6226	WICK CAM ACTUATION PLATE
5A	24	158-6233A	CAM SHAFT FOR 8-PAD - CROSSFIRE
5A	25	158-8223	WICK PLATE ASSEMBLY 3.125 INCH - CROSSFIRE
5A	26	158-8227	WICK PLATE ASSEMBLY 7.125 INCH - CROSSFIRE

230V FUSE CHART

F1	315mA	154-1263E
F2	6.3AMP	154-1268E
F3	4 AMP	154-1267E
F4	4 AMP	154-1267E
F5	1.6 AMP	154-1265E
F6	1.6 AMP	154-1265E
F7	1.6 AMP	154-1265E
F8	8 AMP C.B.	153-1810
F9	1.6 AMP	154-1265E
F10	1.6 AMP	154-1265E
F11	1.6 AMP	154-1265E
F12	315mA	154-1260E

115V FUSE CHART

F1	0.75 AMP	154-1262
F2	7.5AMP	154-1268
F3	4 AMP	154-1268C
F4	4 AMP	154-1268C
F5	2.5 AMP	154-1266
F6	2.5 AMP	154-1266
F7	2.5 AMP	154-1266
F8	10 AMP	154-1273
F9	2.5 AMP	154-1266
F10	2.5 AMP	154-1266
F11	2.5 AMP	154-1266
F12	0.75 AMP	154-1262

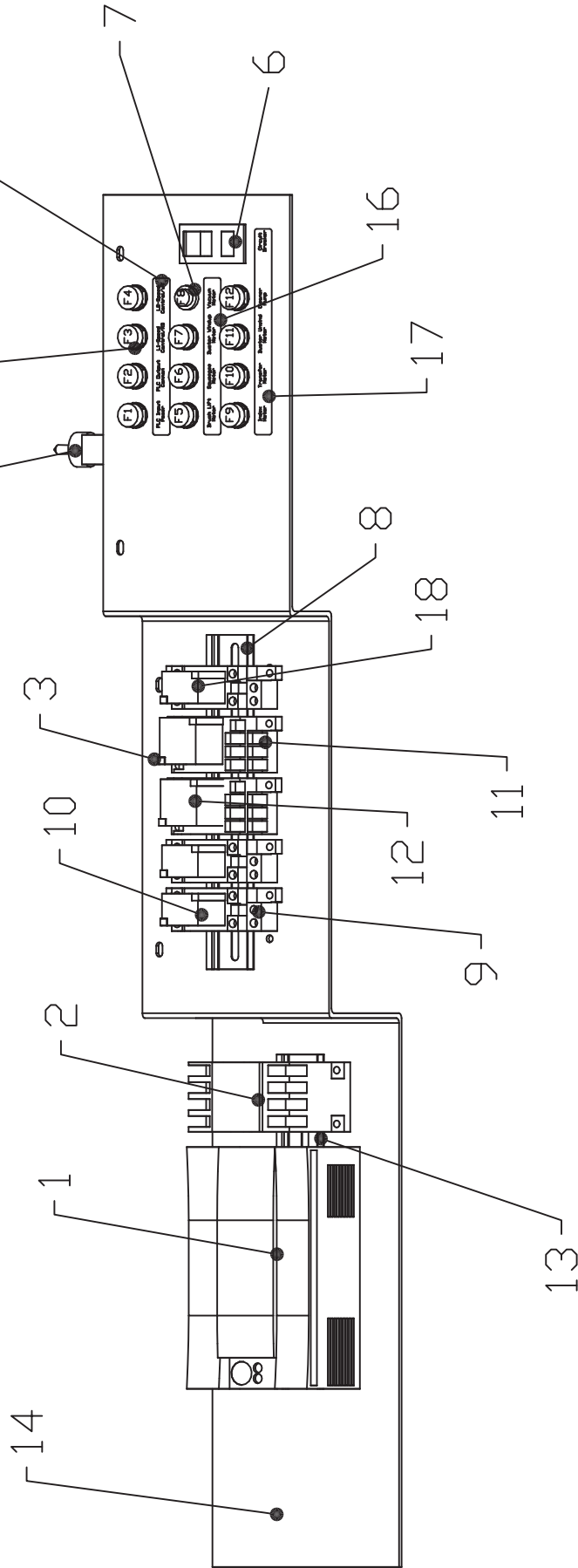
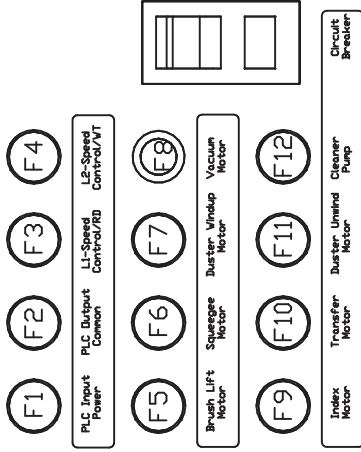

FIGURE 6

FIGURE 6 PART NUMBERS

FIGURE NUMBER	INDEX NUMBER	PART NUMBER	PART NAME & DESCRIPTION
6	1	154-1801	PLC - OMRON
6	2	153-1004A	BUFFER MOTOR CONTACTOR (115 VOLT)
6	2	153-1604A	BUFFER MOTOR CONTACTOR (230 VOLT)
6	3	153-1020	RELAY CLAMP (SOLD AS PAIR)
6	4	154-1811	TOGGLE SWITCH SPDT ON-OFF-ON
6	5	153-1028	PANEL-MOUNT FUSE HOLDER - UL (COMPLETE)
6	5	153-1028E	PANEL-MOUNT FUSE HOLDER - IEC (COMPLETE)
6	6	154-1272	CIRCUIT BREAKER - DPST (10A)
6	7	153-1810	CIRCUIT BREAKER - SPST - 8 AMP (230V ONLY)
6	8	153-1809F	DIN RAIL - 8-9/16 INCH
6	9	153-1017	LY2 RELAY BASE
6	10	153-1016D	LY2 RELAY (24VDC)
6	11	153-1019	LY3 RELAY BASE
6	12	153-1018	LY3 RELAY (115 VOLT)
6	12	153-1618	LY3 RELAY (230 VOLT)
6	13	153-1809E	DIN RAIL - 8 INCH
6	14	158-6216	PLC/RELAY MOUNT PLATE
6	15	158-0205	DECAL - FUSE PANEL CROSSFIRE - FIRST ROW
6	16	158-0205A	DECAL - FUSE PANEL CROSSFIRE -SECOND ROW
6	17	158-0205B	DECAL - FUSE PANEL CROSSFIRE - THIRD ROW
6	18	153-1016	LY2 RELAY (115 VOLT)
6	18	153-1616	LY2 RELAY (230 VOLT)

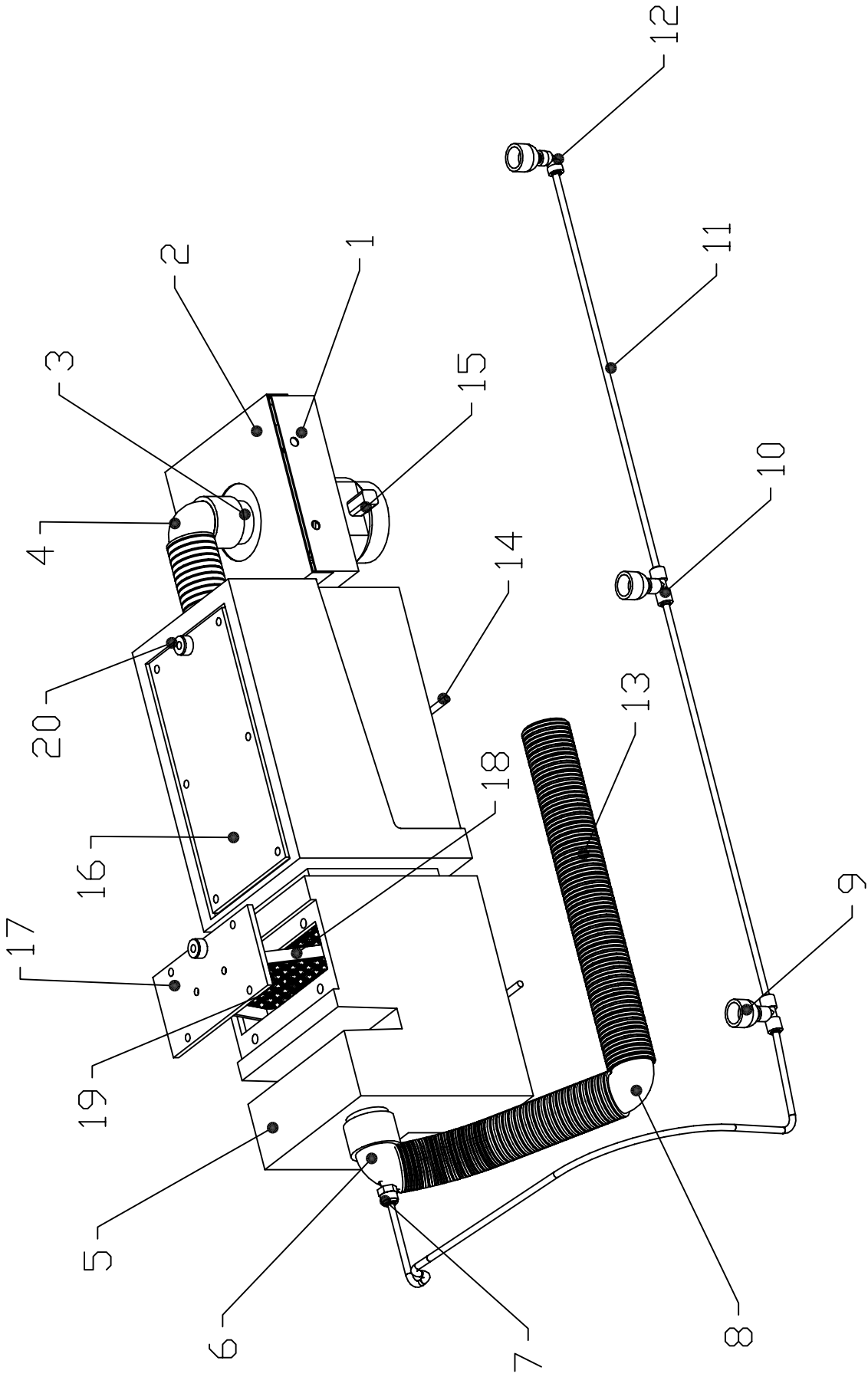

FIGURE 7

FIGURE 7 PART NUMBERS			
FIGURE	INDEX	PART	PART NAME & DESCRIPTION
NUMBER	NUMBER	NUMBER	
7	1	158-6211	VACUUM MOTOR HOUSING - CROSSFIRE
7	2	158-6212	VACUUM MOTOR TOP PLATE - CROSSFIRE
7	3	158-8207	VACUUM NIPPLE ASSEMBLY - CROSSFIRE
7	4	153-8827T	1-1/4 PVC ELBOW-TANK INLET (NO THREADS)
7	5	153-8841	RECOVERY TANK ASSEMBLY - MOLDED
7	6	158-6244	ELBOW - RECOVERY TANK W/TAPPED HOLE
7	7	154-0858	MALE CONNECTOR-1/4 TUBE-1/4 NPTF
7	8	154-0607	PVC ELBOW - 1-1/2 BARB X 1-1/2 BARB
7	9	158-6254	SPRAY JET SUCTION CUP
7	10	153-0815	UNION TEE (1/4 X 1/4 X 1/4-QUICK DISC)
7	11	154-0202A	PENCIL TUBING STOCK - 1/4" OD X 1/8" ID
7	12	154-0243	ELBOW (90 DEGREE) 1/4 X 1/4 (GUEST)
7	13	154-0260	FLEXIBLE VACUUM HOSE STOCK (1-1/2" ID)
7	14	153-2221C	ALL THREAD 1/4-20 X 8.5 INCHES
7	15	158-8208	VACUUM MOTOR ASSEMBLY 115V - CROSSFIRE
7	15	158-8208E	VACUUM MOTOR ASSEMBLY 230V - CROSSFIRE
7	16	153-6841Y	RECOVERY TANK COVER
7	17	153-6841Z	RECOVERY TANK FILTER COVER
7	18	154-6735	FILTER MEDIA RETAINER
7	19	153-8844	RECOVERY TANK FILTER REPLACEMENT KIT
7	20	154-0006A	BUMPER GUARD - POLYURETHANE (13/32)

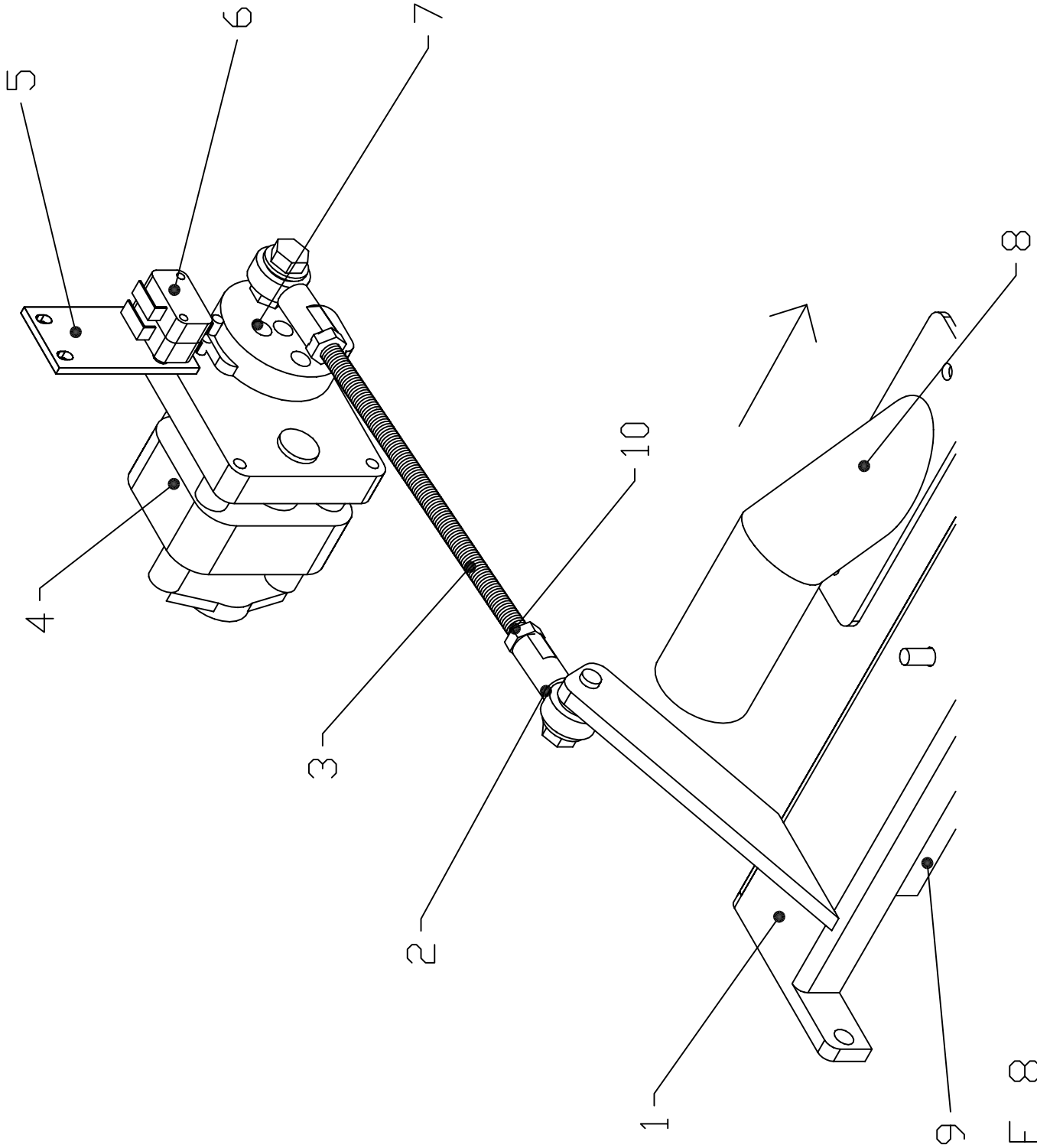

FIGURE 8

FIGURE 8 PART NUMBERS

FIGURE NUMBER	INDEX NUMBER	PART NUMBER	PART NAME & DESCRIPTION
8	1	154-6339-2133	SQUEEGEE MOUNT ANGLE
8	2	153-0211	SQUEEGEE ROD END WITH FITTING (ON MOTOR)
8	3	154-0031	5/16-24 ALLTHREAD STOCK
8	4	153-8207	BRAKE MOTOR ASSEMBLY (25 RPM-115V 60Hz)
8	4	153-8807H	BRAKE MOTOR ASSEMBLY (25 RPM-230V 50 Hz)
8	5	154-6824	BRUSH CAM SWITCH PLATE
8	6	153-1203	MICROSWITCH W/ ROLLER
8	7	154-6243	MOTOR CAM - DUAL LOBES
8	8	154-6677	SQUEEGEE HOSE ADAPTER
8	9	153-0202	SQUEEGEE ASSEMBLY - BLUE
8	9	153-0202B	SQUEEGEE REPLACEMENT BLADES - BLUE
8	10	153-2214	JAM NUT - 5/16-24

RIGHT SIDE

LEFT SIDE

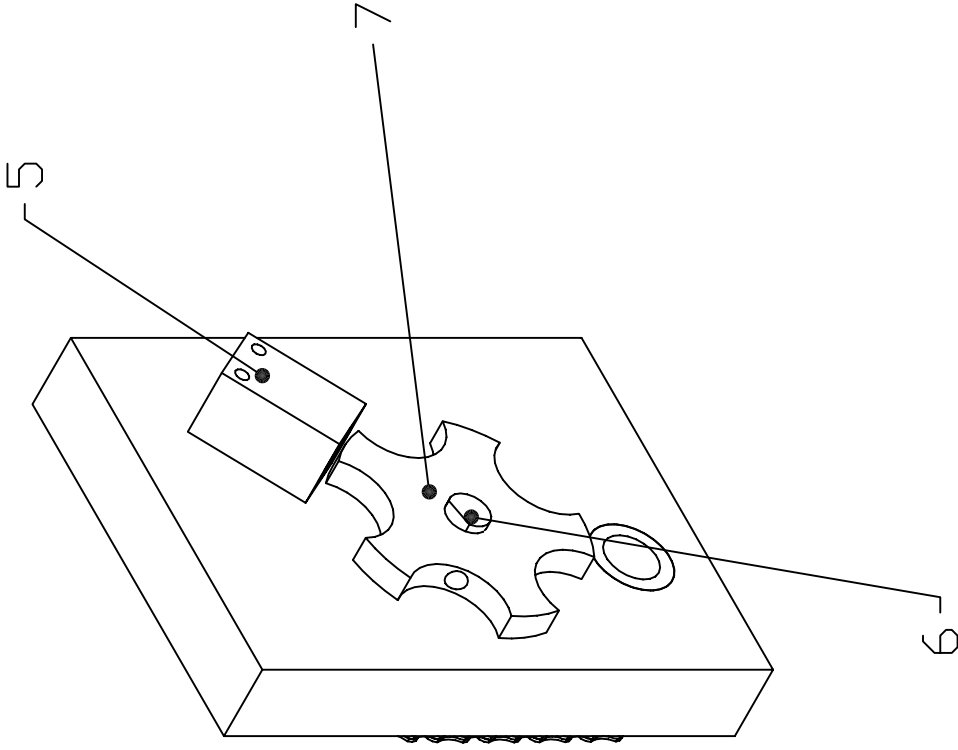
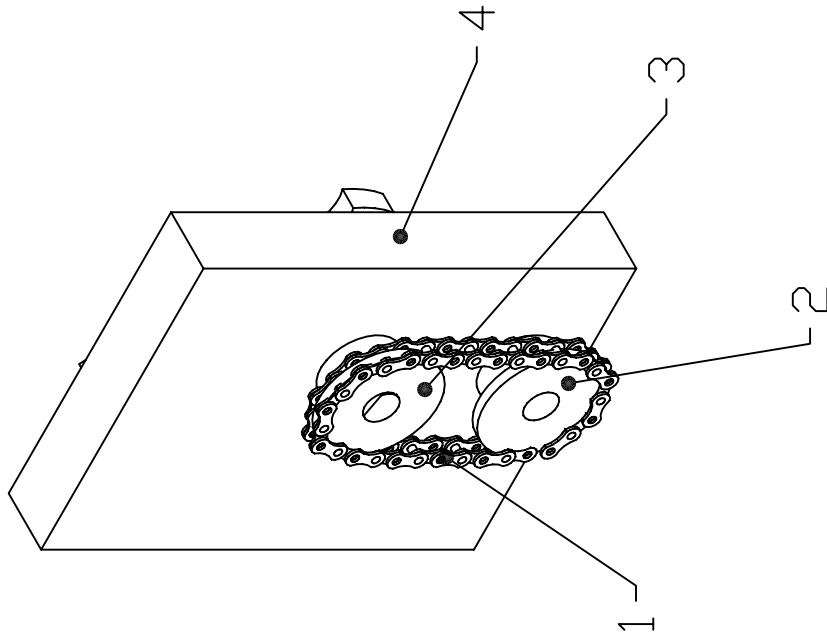

04:07

FIGURE 9

FIGURE 9 PART NUMBERS

FIGURE NUMBER	INDEX NUMBER	PART NUMBER	PART NAME & DESCRIPTION
9	1	154-9211	LDS AND TACH SENSOR DRIVE CHAIN (25P29)
9	2	154-9213	SPROCKET - 25B15 (TACH AND LDS DRIVE 1/2" BORE)
9	3	153-9010	SPROCKET - 25B15 (TRANSFER DRIVE & LDS - 3/8")
9	4	154-8320	PILLOWBLOCK - LANE DISTANCE SHAFT (CENTER-PLAIN)
9	5	154-1220	PROXIMITY SENSOR
9	6	154-6264	SHAFT FOR TIMING DISK (REMOTE SENSOR)
9	7	154-6717	5-TOOTH ALUMINUM DISK (3/8 BORE)

RIGHT SIDE

LEFT SIDE

04:07

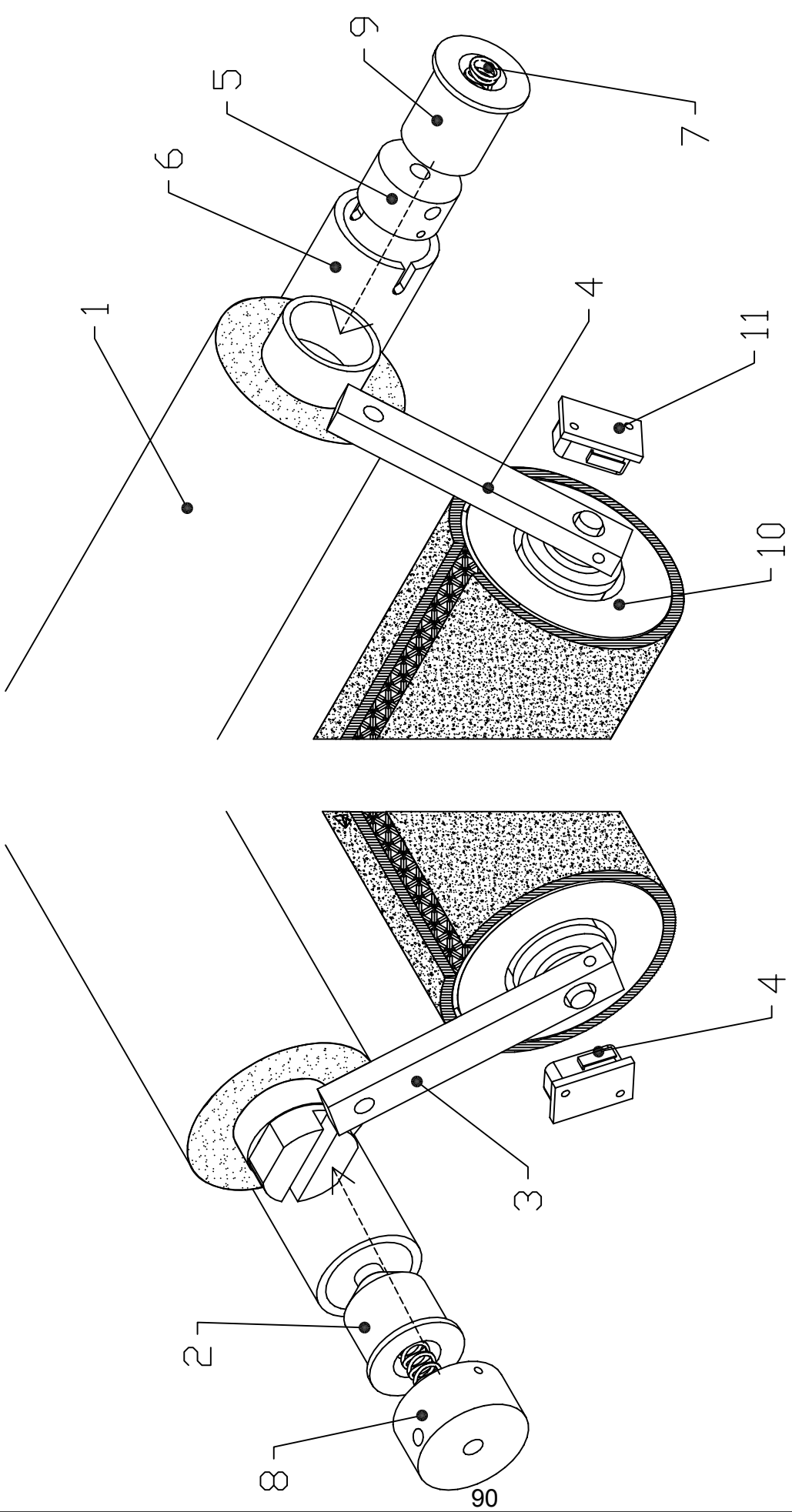

FIGURE 10

FIGURE 10 PART NUMBERS			
FIGURE	INDEX	PART	PART NAME & DESCRIPTION
NUMBER	NUMBER	NUMBER	
10	1	153-0047EZ	DUSTER CLOTH
10	2	153-6850	UHMW DUSTER PLUG FOR CARDBOARD CORE
10	3	153-8420	CUSHION ROLLER PIVOT ARM ASSEMBLY
10	4	153-1202	MICROSWITCH-WITHOUT ROLLER
10	5	153-8202B	DUSTER SOLID DRIVE HUB (PVC-1/4-28)
10	6	153-8824	PVC TAKE-UP REEL ASSEMBLY (44-3/4")
10	7	153-2808	SPRING - 0.42 OD X 1.25 (DUSTER PLUG)
10	8	153-8201B	DUSTER DRIVE HUB ASSEMBLY (1/4-28)
10	9	153-6853	UHMW DUSTER PLUG FOR PVC TAKE-UP REEL
10	10	153-8838	CUSHION ROLLER (STEEL=44-3/8)
10	11	158-6240	DUSTER SWITCH MOUNT PLATE

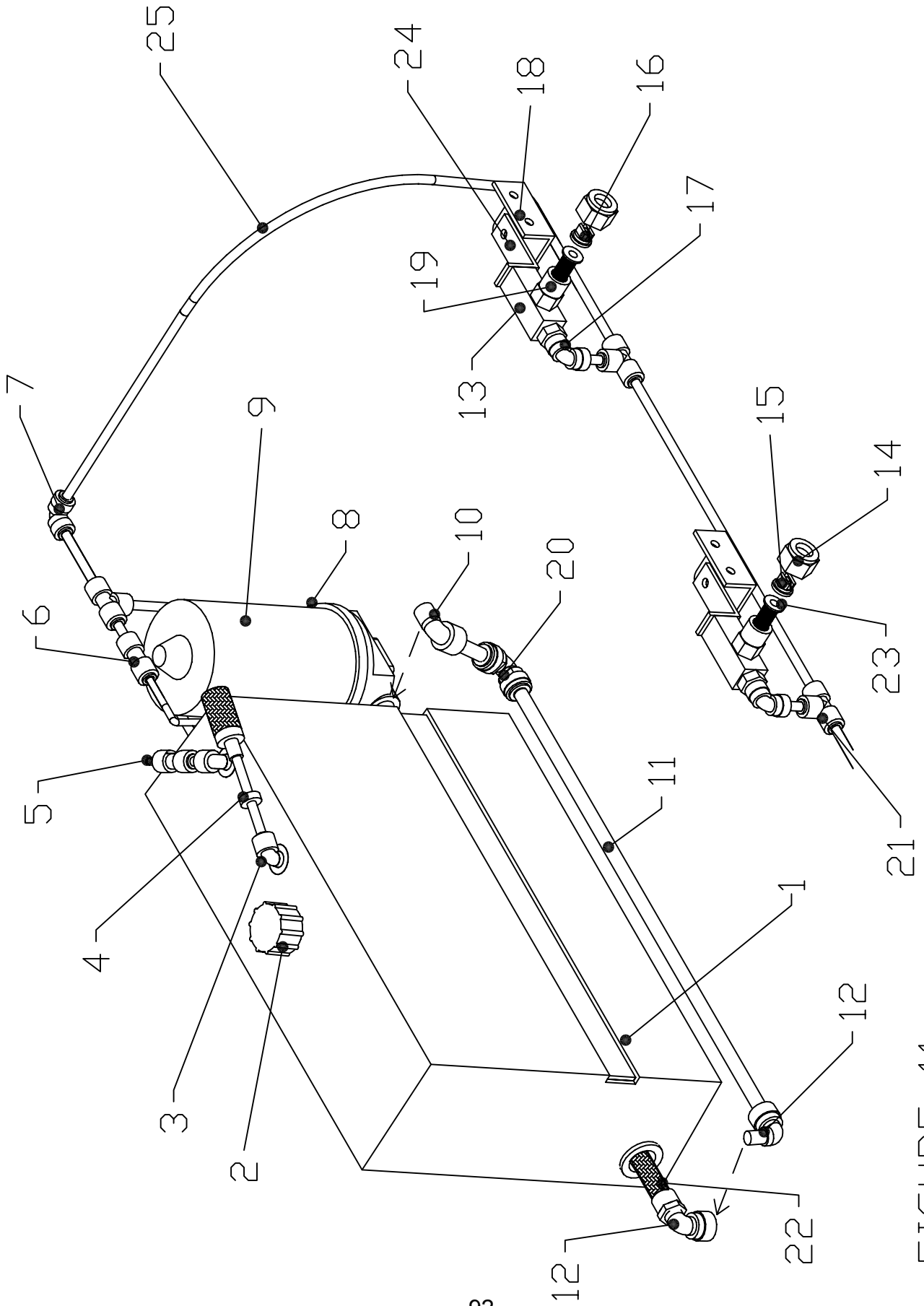

FIGURE 11

FIGURE 11 PART NUMBERS			
FIGURE NUMBER	INDEX NUMBER	PART NUMBER	PART NAME & DESCRIPTION
11	1	154-6723	CLEANER SUPPLY TANK (NO FITTINGS)
11	1	154-8840	CLEANER SUPPLY TANK (COMPLETE)
11	2	154-0832	GARDEN HOSE FITTING CAP W/ GASKET
11	3	154-0223	ELBOW (90 DEGREE) - 1/4 NPT X 1/4" TUBE
11	4	154-8817	MANUAL VENT VALVE ASSEMBLY
11	5	154-0202B	PENCIL TUBING STOCK-3/16" OD X 1/16" ID
11	6	154-0248	REDUCING UNION CONNECTOR-1/4" X 3/16"
11	7	154-0243	ELBOW (90 DEGREE) 1/4 X 1/4 (GUEST)
11	8	154-0412	ELBOW - 3/8 NPT X 1/4 TUBE
11	9	153-8206F	WATER PUMP-FLOJET 115V
11	9	153-8206H	WATER PUMP-FLOJET 230V
11	10	154-0803	ELBOW - 3/8 NPT X 3/8" TUBE
11	11	154-0202	PUMP TUBING STOCK (3/8" OD X 1/4" ID)
11	12	154-0225	ELBOW - 3/8 TUBE OD X 1/4 NPT
11	13	153-6252	SPRAY JET BODY
11	14	153-0218	TIP RETAINER CAP CONNECTOR
11	15	153-0207A	SPRAY TIP - STAINLESS STEEL (11003)
11	16	154-0007	SPRAY TIP - STAINLESS STEEL (1501)
11	17	153-0818	MALE SWIVEL ELBOW - 1/4 TUBE-1/4 NPT
11	18	158-6231	SPRAY JET WALL MOUNT ANGLE - CROSSFIRE
11	19	153-0217	MALE BODY (1/4 - NYLON)
11	20	154-0256	ELBOW - 3/8 TUBE X 3/8 TUBE
11	21	153-0815	UNION TEE (1/4 X 1/4 X 1/4-QUICK DISC)
11	22	154-0212B	FILTER FOR SUPPLY TANK (5" SS) PVC
11	23	153-0220	SCREEN CHECK VALVE (POLYPROPYLENE - 10#)
11	24	153-6251S	SPRAY JET SWIVEL MOUNTING ANGLE
11	25	154-0202A	PENCIL TUBING STOCK - 1/4" OD X 1/8" ID

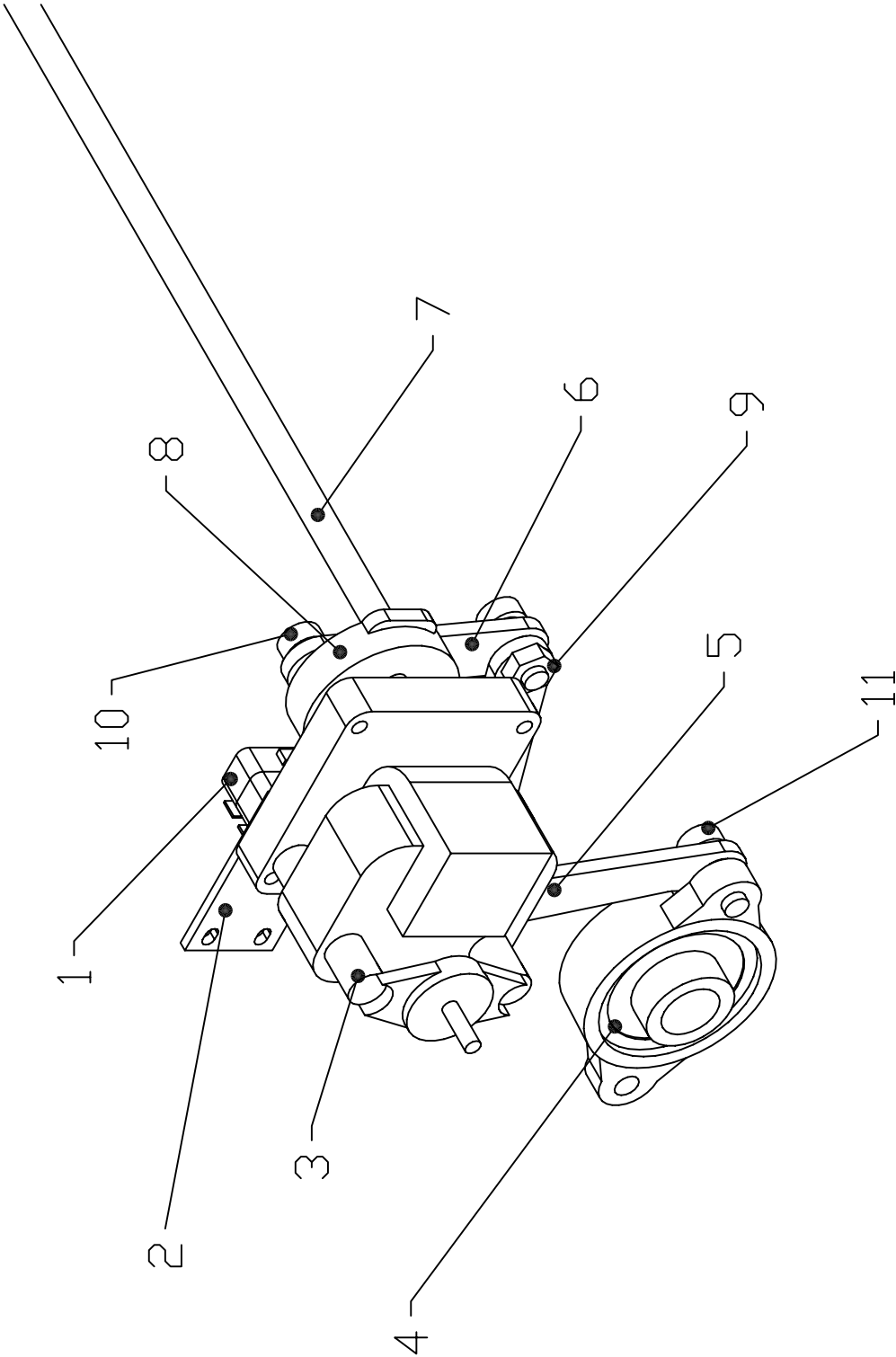

FIGURE 12

FIGURE 12 PART NUMBERS

FIGURE NUMBER	INDEX NUMBER	PART NUMBER	PART NAME & DESCRIPTION
12	1	153-1203	MICROSWITCH-WITH ROLLER (SQUEEGEE/BRUSH)
12	2	154-6824	BRUSH CAM SWITCH PLATE
12	3	153-8207	BRAKE MOTOR ASSEMBLY (25 RPM-115V 60Hz)
12	3	153-8807H	BRAKE MOTOR ASSEMBLY (25 RPM-230V 50 Hz)
12	4	154-8640	FLANGED BEARING-STD BRUSH (3/4" ROTATED)
12	5	154-8638	BUFFER BRUSH LIFTING LINK - LEFT
12	5	154-8639	BUFFER BRUSH LIFTING LINK - RIGHT (NOT SHOWN)
12	6	154-8837	CAM TO BRUSH LIFTING ROD LINK ASSEMBLY
12	7	154-8637	BUFFER BRUSH LIFTING ASSEMBLY
12	8	154-6243	MOTOR CAM-DUAL LOBES (STACKED SWITCHES)
12	9	153-2027A	JAM NUT - 5/16-18
12	10	153-2801	SHOULDER BOLT-3/8 X 3/8 (5/16-18)
12	11	153-2801A	SHOULDER BOLT-3/8 X 11/32 (5/16-18)

Crossfire Wiring Diagrams

The following diagrams show wiring schematics for this lane machine. If you have any questions please call 863-734-0200 or email tech@kegel.net .

Crossfire Wiring 1.....	97
Crossfire Wiring 2.....	98
Crossfire Wiring 3.....	99
Crossfire Wiring 4.....	100

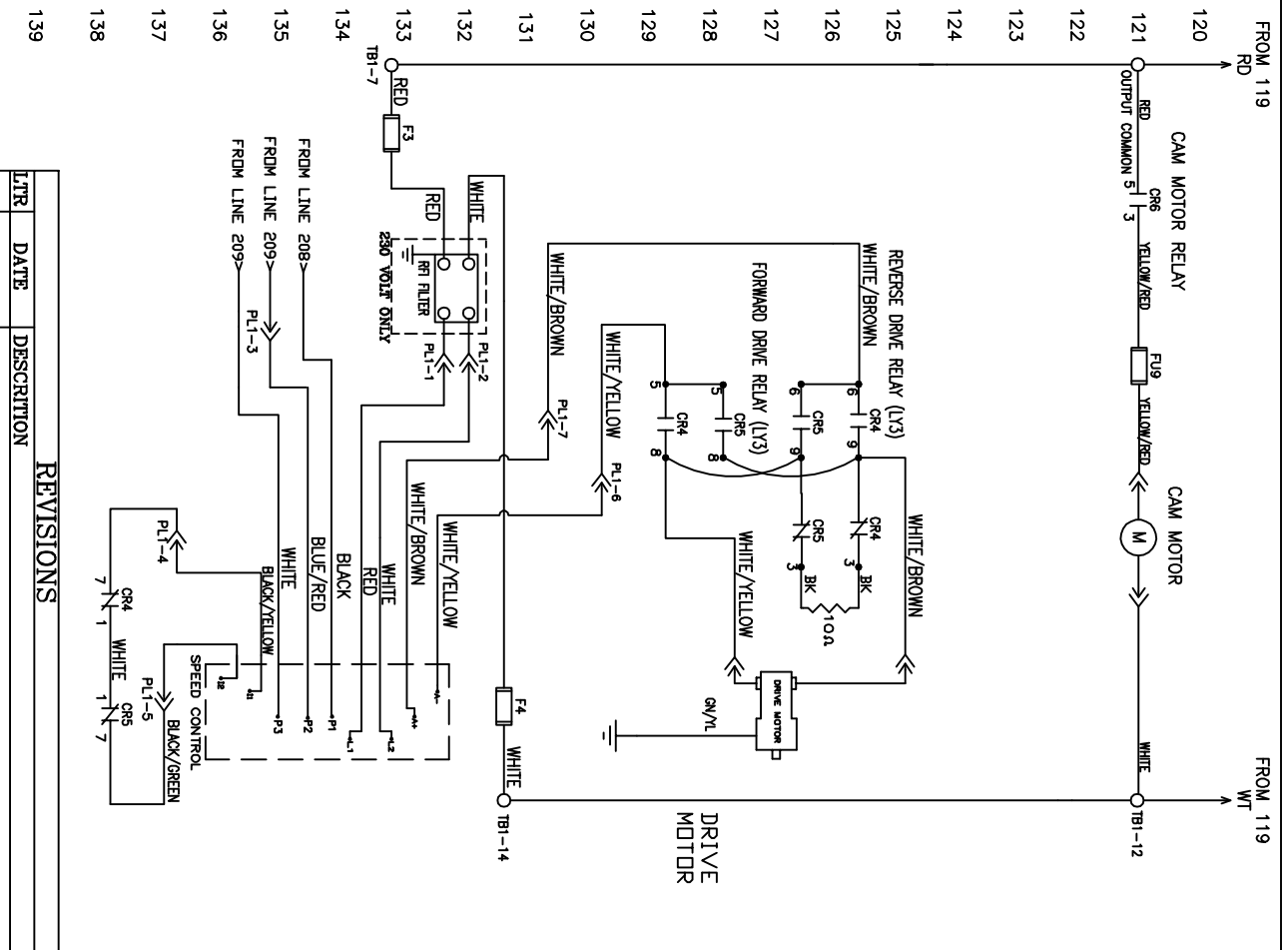
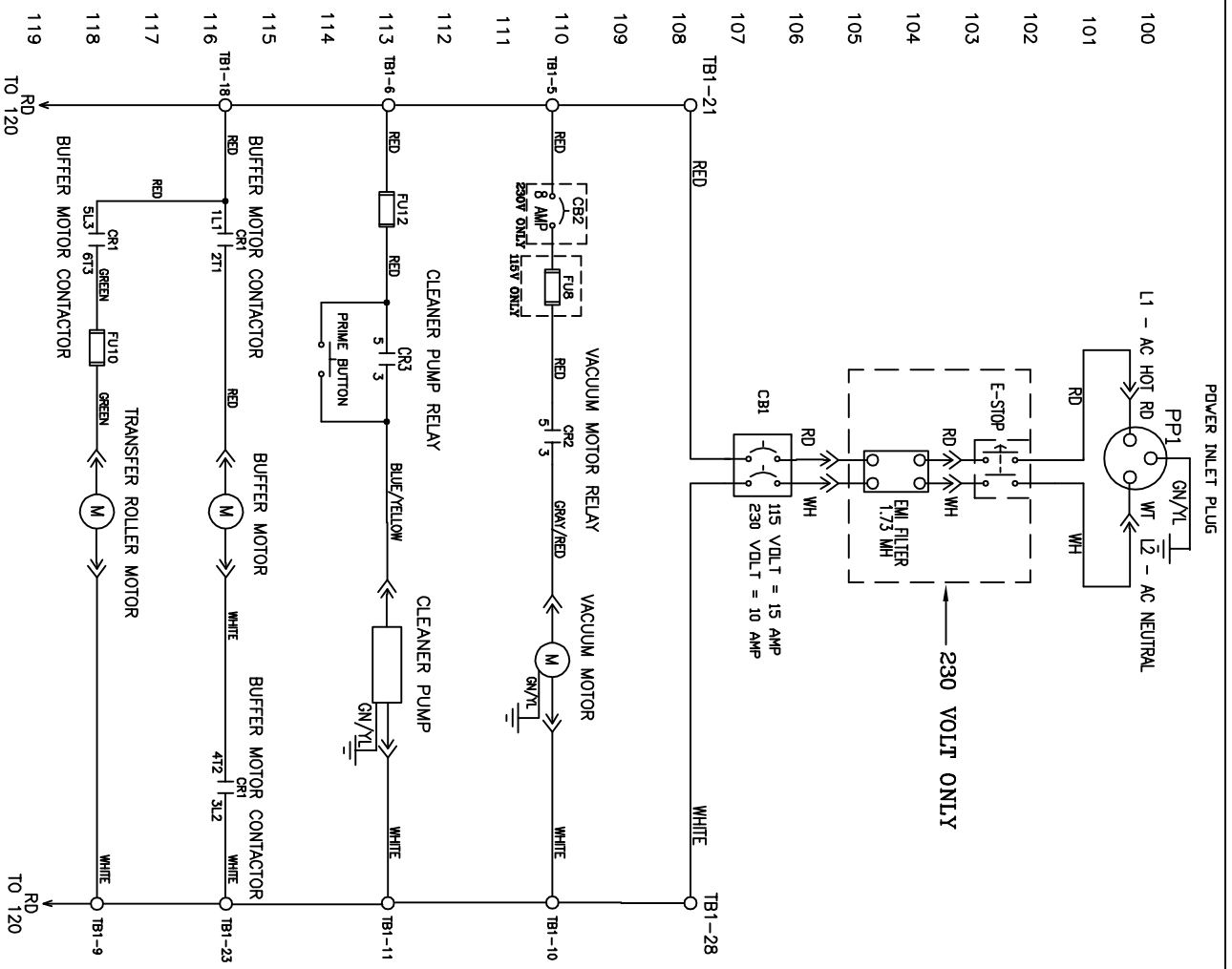

LEGEND

CBI - MACHINE CIRCUIT BREAKER
 CBR - VACUUM MOTOR CIRCUIT BREAKER
 P1.1 - DC SPEED BOARD PLUG (C2)
 P1.2 - AUXILIARY DTL TANK (C6)
 TBI - TERMINAL BLOCK 2 (MAIN) NOTE: POSITION #1 IN TBI IS BLUE, TOP LEFT
 TBS - TERMINAL BLOCK 3 (CLASS) NOTE: POSITION #1 LWR LEFT, GREY
 TBS - TERMINAL BLOCK 3 (HANDLES) NOTE: POSITION #1 IS LWR LEFT, GREY

NOTE: ITEMS IN HIDDEN LINES ARE VOLTAGE SPECIFIC

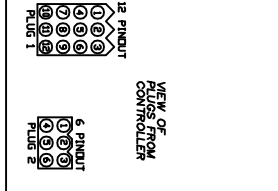

FUSE NO.	115 VOLT MACHINE	230 VOLT MACHINE
1	.75 AMP FUSE	800ma AMP FUSE
2	4 AMP FUSE	4 AMP FUSE
3	4 AMP FUSE	4 AMP FUSE
4	4 AMP FUSE	4 AMP FUSE
5	2.25 AMP FUSE	1.6 AMP FUSE
6	2.25 AMP FUSE	1.6 AMP FUSE
7	2.25 AMP FUSE	1.6 AMP FUSE
8	10 AMP FUSE	1.6 AMP FUSE
9	2.25 AMP FUSE	1.6 AMP FUSE
10	2.25 AMP FUSE	1.6 AMP FUSE
11	2.25 AMP FUSE	1.6 AMP FUSE
12	.75 AMP FUSE	315ma AMP FUSE
CBI	15 AMP C. B.	10 AMP C. B.
CB2		8 AMP C. B.

DATE	DESCRIPTION	REVISIONS

MATERIAL		DESCRIPTION	
KEGEL LLC		CROSSFIRE 115/230 VOLT	
1951 LONGLEAF BLVD.		WIRING DIAGRAM - MODEL C	
LAKE WALES, FL 33856		DO NOT SCALE DRAWING	
(863) 734-0200		SIZE	SCALE
DRAWN BY SLS		QTY/MACHINE	PART NUMBER
DATE 08/20/11		17-5200/17-5250	
APPROVED: SET		SCALE	SHEET 1 OF 4
DOC REV			

DMIRON SYSMAC
CP1L OUTPUTS

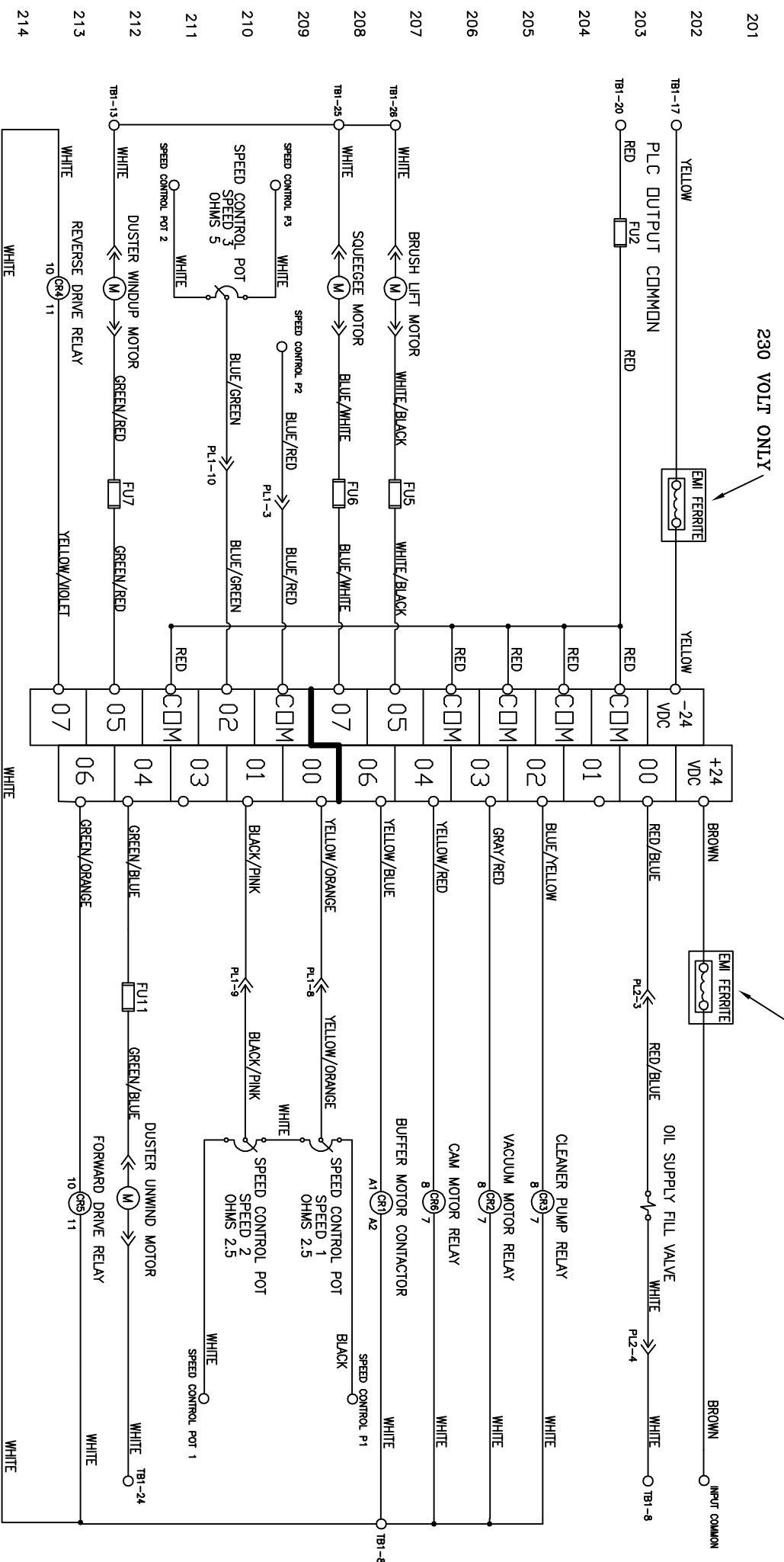

215

LEGEND

- CB1 - MACHINE CIRCUIT BREAKER
- CB2 - VACUUM MOTOR CIRCUIT BREAKER
- PL1 - DC SPEED BOARD PLUG (12)
- PL2 - AUXILIARY OIL TANK (6)
- PL3 - TERMINAL BLOCK 1 (MAIN) NOTE: POSITION #1 IN TB IS BLUE TOP LEFT
- PL4 - TERMINAL BLOCK 2 (LVS) NOTE: POSITION #1 LVR LEFT GREY
- PL5 - TERMINAL BLOCK 3 (HANDLED) NOTE: POSITION #1 IS LVR LEFT GREY

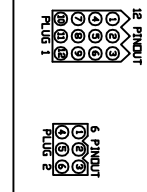

FUSE NO.	115 VOLT MACHINE	230 VOLT MACHINE
1	.75 AMP FUSE	800mA AMP FUSE
2	4 AMP FUSE	4 AMP FUSE
3	4 AMP FUSE	4 AMP FUSE
4	4 AMP FUSE	4 AMP FUSE
5	2.25 AMP FUSE	1.6 AMP FUSE
6	2.25 AMP FUSE	1.6 AMP FUSE
7	2.25 AMP FUSE	1.6 AMP FUSE
8	10 AMP FUSE	1.6 AMP FUSE
9	2.25 AMP FUSE	1.6 AMP FUSE
10	2.25 AMP FUSE	1.6 AMP FUSE
11	2.25 AMP FUSE	1.6 AMP FUSE
12	.75 AMP FUSE	315mA AMP FUSE
CB1	15 AMP C. B.	10 AMP C. B.
CB2		8 AMP C. B.

REVISIONS	
LTTR	DESCRIPTION
A	2/19/2016 CHANGED PLC E/C# 16103

MATERIAL	
QTY	DESCRIPTION
	KEGEL LLC
	CROSSFIRE OUTPUT WIRING
	SCHEMATIC - MODEL C
	DO NOT SCALE DRAWING

DATE	BY	SCALE
2/19/16	SLS	C

DATE	BY	SCALE
08/19/11	SLS	C

DATE	BY	SCALE
2/19/16	SET	C

DATE	BY	SCALE
2/19/16	SET	C

1961 LONGLEAF BLVD.
LAKE WALES, FL 33859
(863) 794-0200

17-5200/17-5250
SHEET 2 OF 4

DMIRON SYSMAC
CPL INPUTS

PLC INPUT POWER

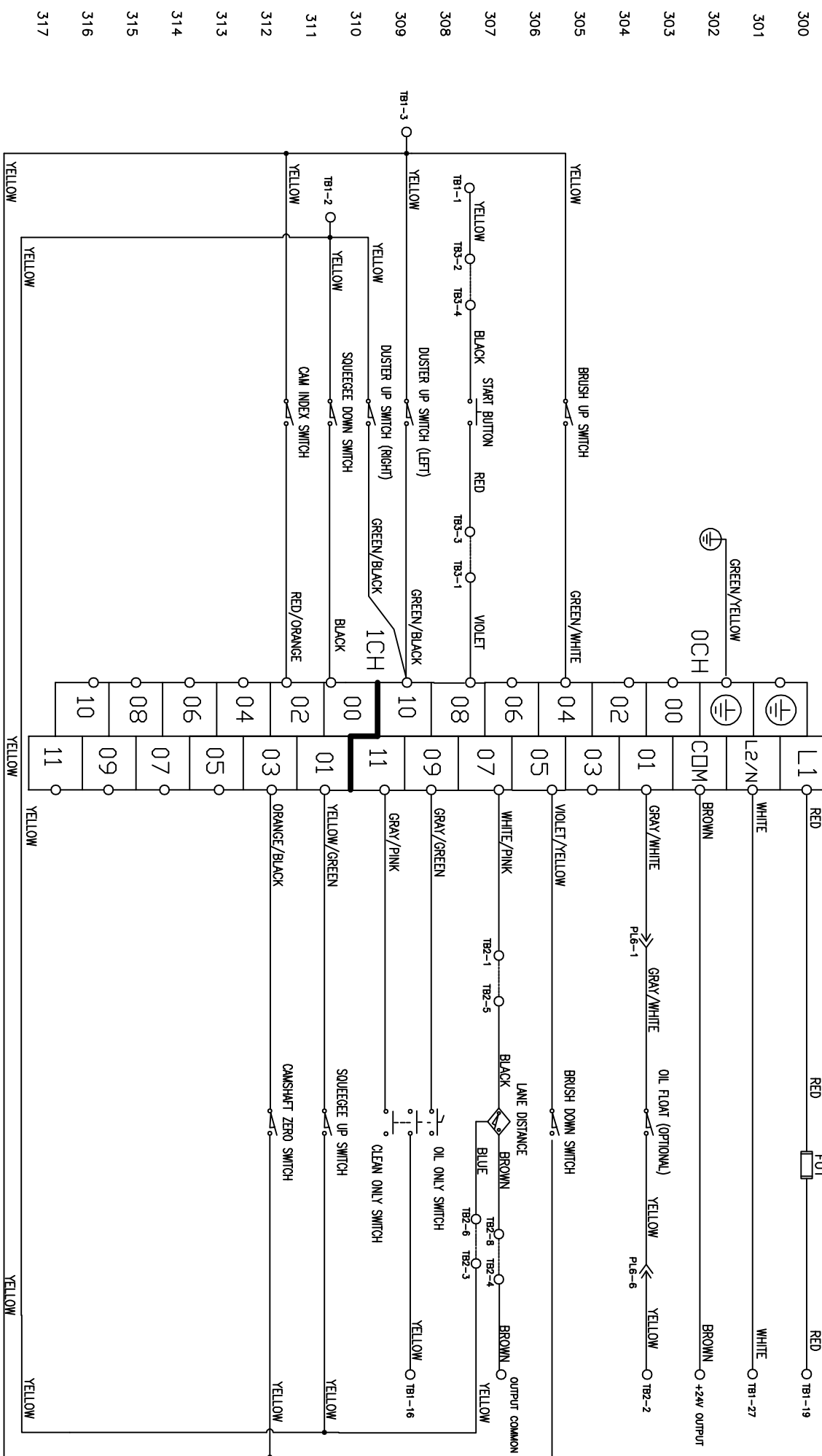

LEGEND

- CB1 - MACHINE CIRCUIT BREAKER
- CB2 - VACUUM MOTOR CIRCUIT BREAKER
- PL1 - DC SPEED BOARD PLUG (K2)
- PL2 - AUXILIARY OIL TANK (6)
- TB1 - TERMINAL BLOCK 1 (MAIN) NOTE: POSITION #1 IN TB IS BLUE TOP LEFT
- TB2 - TERMINAL BLOCK 2 (LDS) NOTE: POSITION #1 LWR LEFT GREY
- TB3 - TERMINAL BLOCK 3 (HANDLE) NOTE: POSITION #1 IS LWR LEFT GREY

NOTE: ITEMS IN HIDDEN LINES ARE VOLTAGE SPECIFIC.

FUSE NO.	115 VOLT MACHINE	230 VOLT MACHINE
1	.75 AMP FUSE	800MA AMP FUSE
2	4 AMP FUSE	4 AMP FUSE
3	4 AMP FUSE	4 AMP FUSE
4	4 AMP FUSE	4 AMP FUSE
5	2.25 AMP FUSE	1.6 AMP FUSE
6	2.25 AMP FUSE	1.6 AMP FUSE
7	2.25 AMP FUSE	1.6 AMP FUSE
8	10 AMP FUSE	1.6 AMP FUSE
9	2.25 AMP FUSE	1.6 AMP FUSE
10	2.25 AMP FUSE	1.6 AMP FUSE
11	2.25 AMP FUSE	1.6 AMP FUSE
12	.75 AMP FUSE	315MA AMP FUSE
CB1	15 AMP C. B.	10 AMP C. B.
CB2	8 AMP C. B.	8 AMP C. B.

REVISIONS

LTR	DATE	DESCRIPTION
A	2/19/16	CHANGED PLC E/C# 16103

MATERIAL

KEGEL LLC
1861 LONGLEAF BLVD.
LAKE WALES, FL 33859
(866) 794-0200

DESCRIPTION
CROSSFIRE INPUT WIRING
SCHEMATIC - MODEL C
DO NOT SCALE DRAWING

REVISIONS

DOC	REV	DATE	SCALE	SHEET	OF
DOC	REV	2/19/16	C	3	4

TB-1

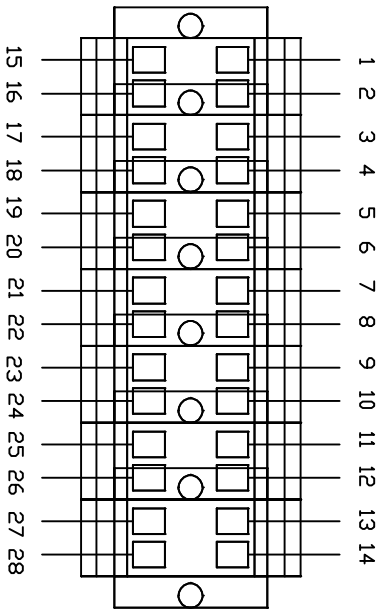

TB-2

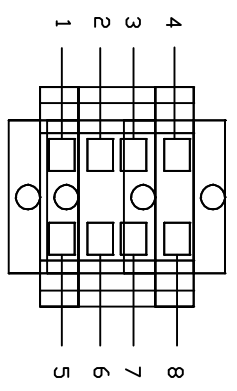

TB-3

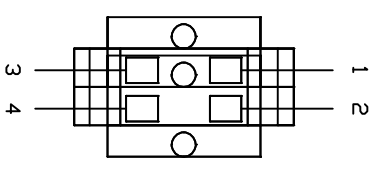

LEGEND

- CB1 - MACHINE CIRCUIT BREAKER
- CB2 - VACUUM MOTOR CIRCUIT BREAKER
- PL1 - DC SPEED BOARD PLUS (E2)
- PL2 - AUXILIARY DR TANK (E3)
- TR1 - TERMINAL BLOCK 5 (HAND) NOTE: POSITION #1 IS BLUE TOP LEFT
- TR2 - TERMINAL BLOCK 5 (HAND) NOTE: POSITION #1 IS GREEN LEFT
- TR3 - TERMINAL BLOCK 5 (HAND) NOTE: POSITION #1 IS LWR LEFT GREY

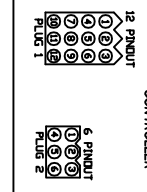

FUSE NO	115 VOLT MACHINE	230 VOLT MACHINE
1	.75 AMP FUSE	800ma AMP FUSE
2	4 AMP FUSE	4 AMP FUSE
3	4 AMP FUSE	4 AMP FUSE
4	4 AMP FUSE	4 AMP FUSE
5	2.25 AMP FUSE	1.6 AMP FUSE
6	2.25 AMP FUSE	1.6 AMP FUSE
7	2.25 AMP FUSE	1.6 AMP FUSE
8	10 AMP FUSE	1.6 AMP FUSE
9	2.25 AMP FUSE	1.6 AMP FUSE
10	2.25 AMP FUSE	1.6 AMP FUSE
11	2.25 AMP FUSE	1.6 AMP FUSE
12	.75 AMP FUSE	315ma AMP FUSE
CB1	15 AMP C. B.	10 AMP C. B.
CB2		8 AMP C. B.

MATERIAL		REVISIONS	
LTR	DATE	DESCRIPTION	
DRAWN BY SLS		DATE 08/20/11	
APPROVED: SET			
DESCRIPTION		KEGEL LLC	1951 LONGLEAF BLVD, LAKE WALES, FL 33859 (863) 794-0200
CROSSFIRE 115/230 VOLT		TERMINAL BLOCK LAYOUT - MODEL C	
DO NOT SCALE DRAWING		SIZE QTY/MACHINE PART NUMBER	17-5200/17-5250
SCALE C		SHEET 4	OF 4



“Take care of your lane machine and it will take care of you”